



BUILD-A-BOX™

Modular Aluminum Trench Shielding System

Purpose:

The Build-A-Box™ Modular Aluminum Trench Shield System can be assembled in minutes to a wide variety of two, three, four, or eight-sided configurations. This flexibility enables work crews to make on-the-spot design changes to meet job requirements in conditions ranging from light to extreme. Most systems are easily transported in a pick-up truck or trailer for quick application.

Common Applications:

- Sewer & Water Valves
- Hydrants & Taps
- Spot Repairs
- Gas and Electric Utility

Features:

- Pick-up truck transportable
- Can be hand-assembled in minutes
- Narrow, smooth aluminum sidewalls reduce dirt build-up
- 8 in. foam-filled extrusions limit added weight if sidewall punctured
- Tongue and groove design
- Foam-filled
- Lifting Lugs
- Professional Engineer design and depth certification

Options:

- T-connection cut-outs
- Sheeting Guide Frame
- Sectional or Full Length corner posts
- 3-Way T-Posts

Spreader Options:

- Telescoping Adjustable Spreaders
- Height Adapters



2-Sided Build-A-Box



3-Sided Build-A-Box



4-Sided Build-A-Box



Build-A-Box Octagon Box

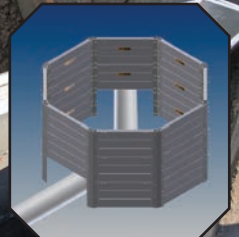

BUILD-A-BOX™

Modular Aluminum Trench Shielding System

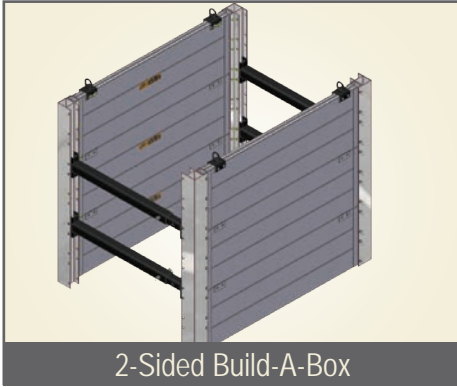

2-Sided Build-A-Box

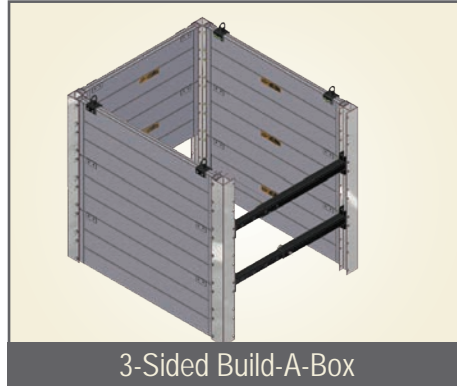

3-Sided Build-A-Box

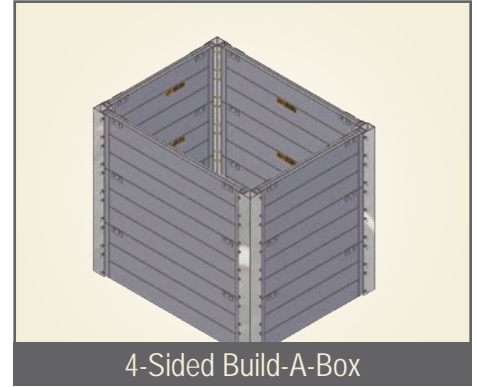

4-Sided Build-A-Box

Build-A-Box™ Modular Trench Shield - Two-Sided w/ Full Length or Sectional Corner Posts					
Panels (2 Ft. High)		Shield Capacity (PSF)	Depth of Cut (ft) - Soil Type		
Model	Weight (Lbs.)		B	C-60	C-80
BAB-2	34	2,400	53	40	30
BAB-3	46	2,400	53	40	30
BAB-4	60	2,400	53	40	30
BAB-5	71	2,400	53	40	30
BAB-6	84	2,400	53	40	30
BAB-7	99	1,740	39	29	22
BAB-8	110	1,440	32	24	18
BAB-9	125	1200	27	20	15
BAB-10	138	960	21	16	12
BAB-12	165	780	17	13	10
BAB-14	190	600	13	10	8
BAB-16	210	480	11	8	6

Corner End Posts		
Model	Length (In.)	Weight (Lbs.)
BAB-C2-2	24	18
BAB-C2-4	48	36
BAB-C2-6	72	53
BAB-C2-8	96	69
BAB-C2-10	120	88
BAB-C2-12	144	126

3-Way T-Posts		
Model	Length (In.)	Weight (Lbs.)
BAB-C3-2	24	19
BAB-C3-4	48	38
BAB-C3-6	72	57
BAB-C3-8	96	75
BAB-C3-10	120	95
BAB-C3-12	144	141

A BAB Sheeting Guide Frames		
Model	Length (In.)	Weight (Lbs.)
BAB-SGF-4	48	119
BAB-SGF-6	72	190
BAB-SGF-8	96	245
BAB-SGF-10	120	316
BBAC-GF-12	144	385

B Aluminum Sheets (with push caps)		
Model	Length (In.)	Weight (Lbs.)
BAB-ALUM-SHEET-6	72"	25 Lbs.
BAB-ALUM-SHEET-8	96"	33 Lbs.

C FILLER PANEL		
Model	Length (In.)	Weight (Lbs.)
BAB-FILLER-8	8"	14 Lbs.

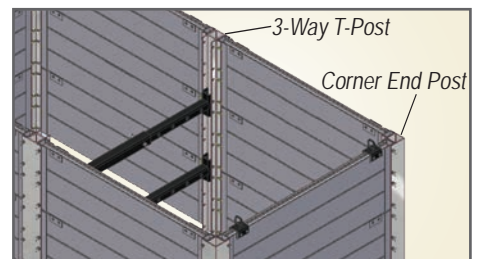
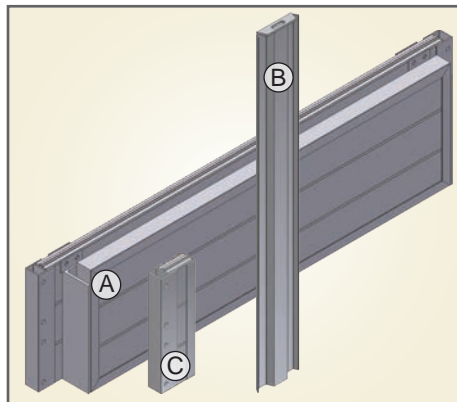

Spreaders Single Adj. Square Tube			
Item	Model	Length (In.)	Weight (Lbs.)
7514	XL-2436-1	24 - 36	35
7515	XL-3660-1	36 - 60	47
7516	XL-4872-1	48 - 72	61
7570	XL-6096-1	60 - 96	76
7518	XL-72120-1	72 - 120	110
7519	XL-84144-1	84 - 144	132

Height Adapters and Extensions			
Model	Description	Weight (Lbs.)	Depth of Cut (ft) C-60 - Soil Type
HABAB72-HEIGHT ADAPTER	72" (high) x 48"	620	14
HAEXT-BAB-24	24" Horiz. Extensions	110	14
HAEXT-BAB-36	36" Horiz. Extensions	140	14
HAEXT-BAB-48	48" Horiz. Extensions	170	14
HAEXT-BAB-60	60" Horiz. Extensions	200	14
HAEXT-BAB-72	72" Horiz. Extensions	230	14
HAEXT-BAB-84	84" Horiz. Extensions	260	14

ACCESSORIES



Height Adapter
Part # HABAB72-HEIGHT ADAPTER



Barrier Posts
Part # BAB-BP

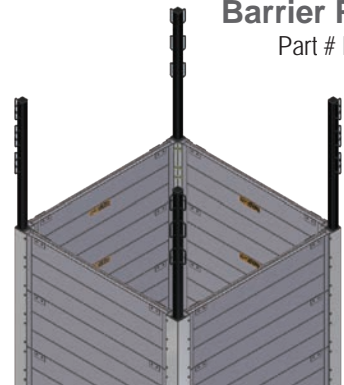

Sheeting Guide Frame
Sheets 6 and 8 ft. lengths



Stacking Guides
Part # BAB-STACKING GUIDE

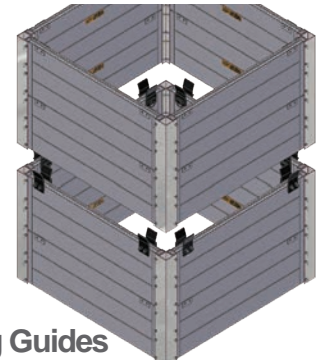

Wheel Kit
Part # BBAC-WK



BTS Clamping Guard Rail
4,8,10, 12 ft. lengths



Adjustable Legs
Part # BAB-24-LEGS

Lifting Lug
Part # BAB-LE

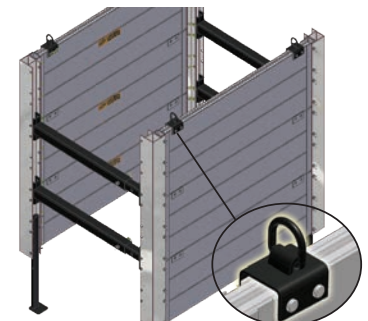

Assembly

Step 1

Attach 1st corner post to first panel and secure with pins and keepers.*
Set the BACK panel for 3 or 4-sided system and secure with pins and keepers in all matching holes.*

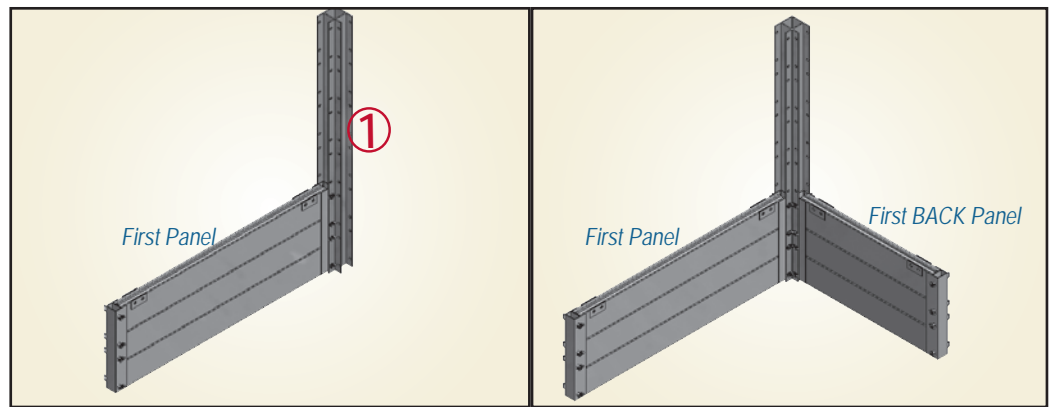

Step 2

Stack the SIDE and BACK panels to desired height before installing the 2nd and 3rd corner posts. Ensure that all matching holes have a pin and keeper.*

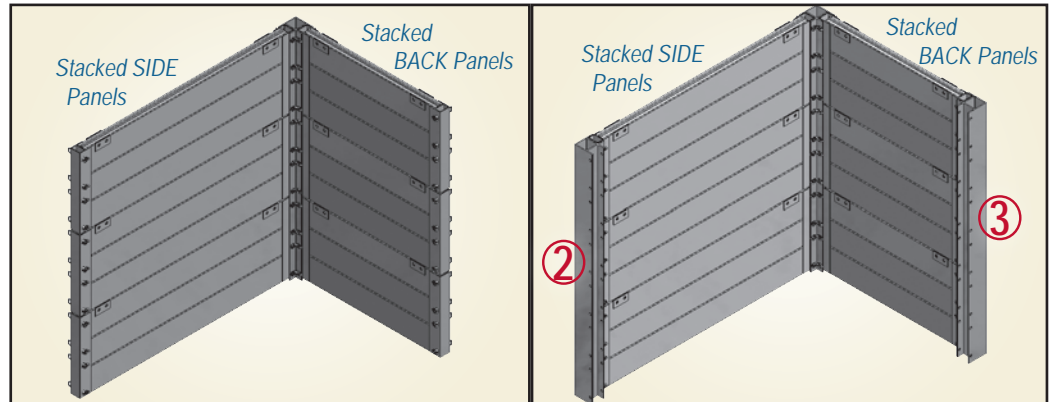

Step 3

Stack opposite SIDE panels to desired height, then add either a 4th wall of panels for a 4-sided system; or a set of at least two spreaders for a 3-sided system.

Step 4

The 4th corner post can then be slid into place. All matching holes require a pin and keeper.*
Note: A pry-bar may be needed to align posts with holes.

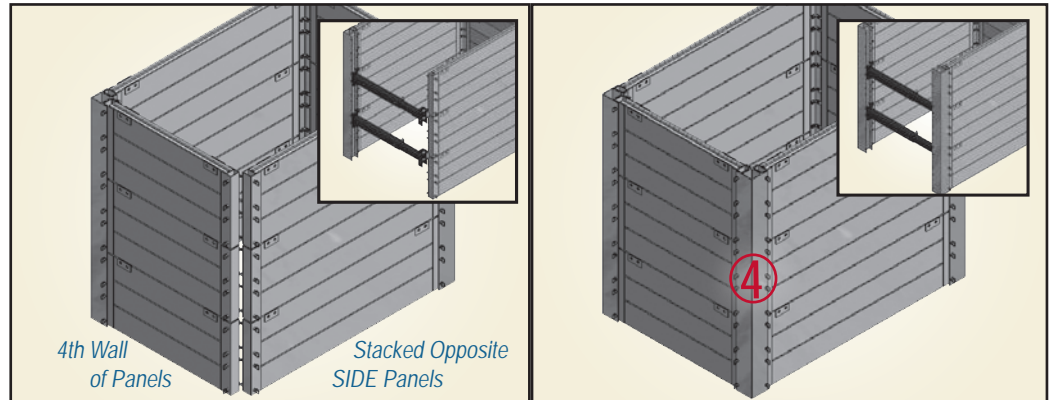

* Always install pins with handle on the outside.

For **Disassembly**: Do above steps in reverse order. Remove pins & keeps one at a time from one spreader, post, or panel. **DO NOT REMOVE ALL PINS AND KEEPERS AT ONE TIME.**

NOTES

1. Assemble on level ground.
2. Lift with factory supplied lift eyes.
3. System must be used in accordance to manufactures tabulated data.
4. Bottom panel may be omitted, allowing 2 feet open clearance, only if there is no possible loss of soil from behind or below the bottom of the shield.

[ASSEMBLY VIDEO](#)



[DISASSEMBLY VIDEO](#)



PRO-TEC EQUIPMENT

4837 West Grand River Ave
Lansing, MI 48906
Phone: 1-800-292-1225
Fax: (517) 827-3263
www.pro-tecequipment.com

ARCOSA
SHORING PRODUCTS